

BASE/VANITY CABINET

1. Place cabinet SIDES in assembly jig with the slotted edges up.
2. Slide the 3" STRIPS into the top female dovetail. (as shown)
Make sure the rabbet is toward the back and the inside of the cabinet, with the grooved edge up.
3. If a TOEBOARD is ordered, insert it into the pre-drilled toeboard holes.

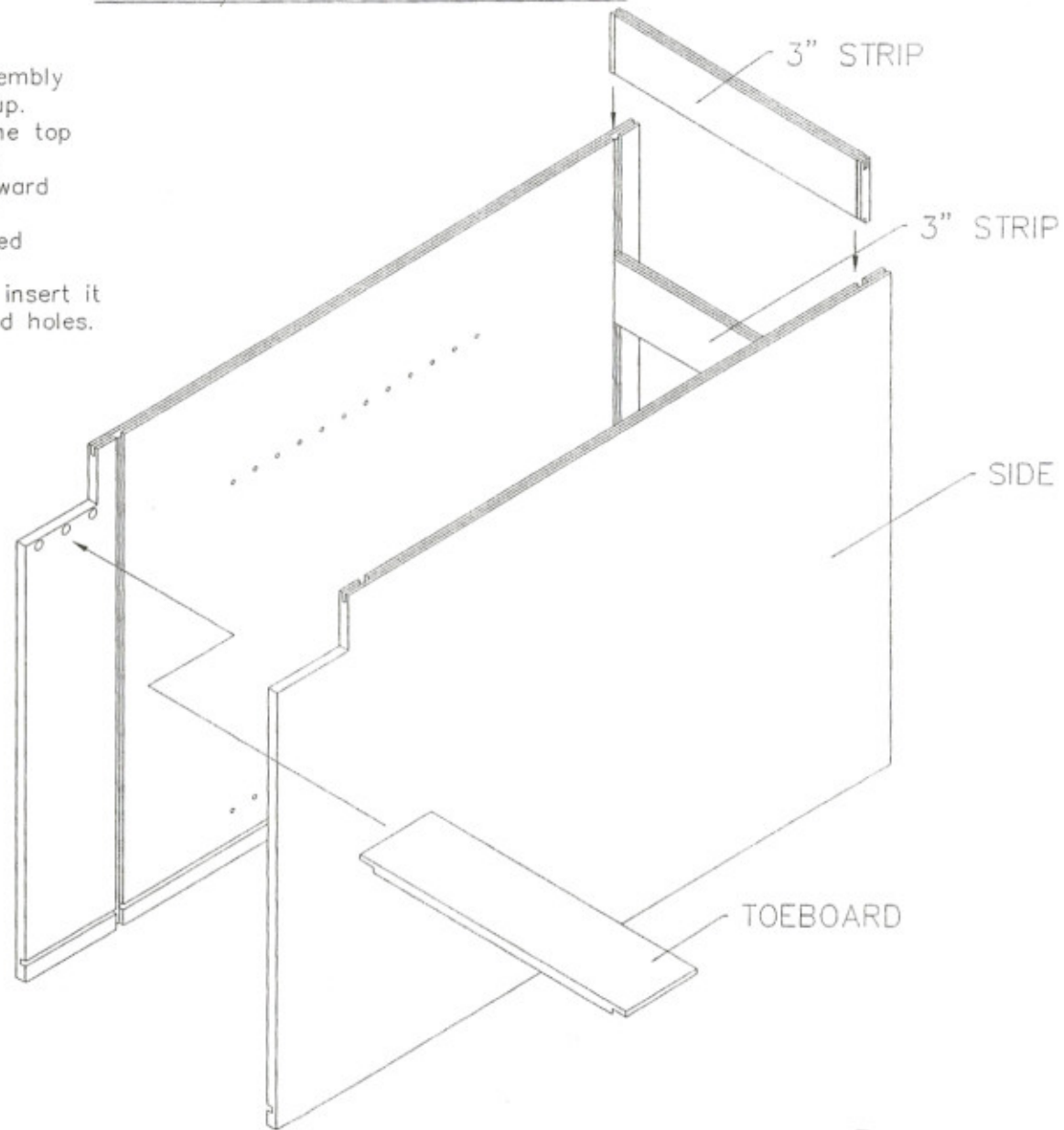

BASE/VANITY CABINET (cont.)

- Slide the cabinet BACK into the ploughs at the back of the SIDES. The BACK will fit into the rabbet on the 3" STRIP.
- Slide the BOTTOM into the cabinet SIDE dovetail. (as shown) Be sure to keep the groove edge up, and rabbet toward the inside of the cabinet. The cabinet BACK will fit into the rabbet on the BOTTOM.

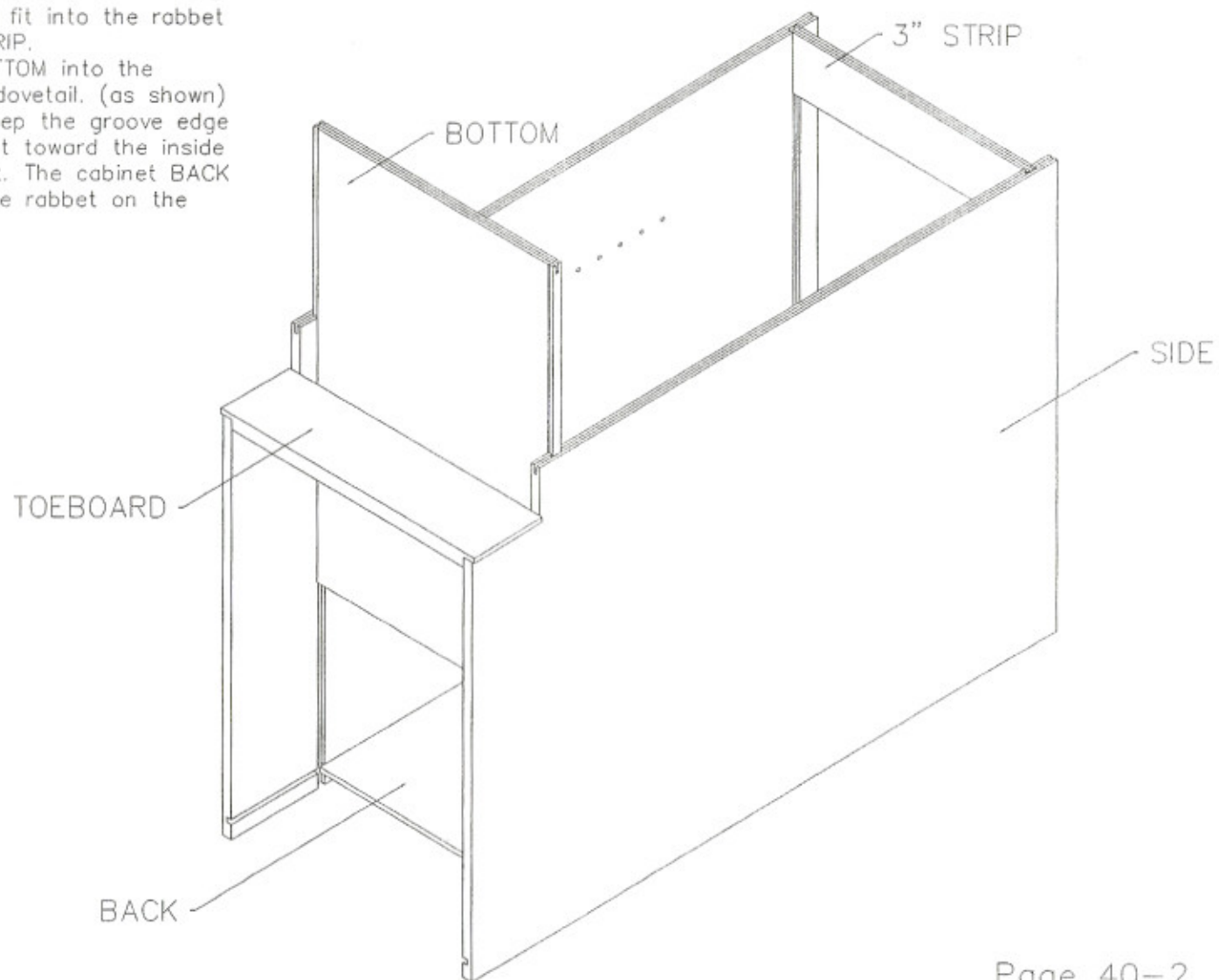

BASE/VANITY CABINET (cont.)

6. Prepare the FRONT FRAME per the instructions on page #2 of this manual.
7. After spreading glue on the slotted edges of the SIDES, TOP and BOTTOM, the FRONT FRAME can now be applied. Matching up the splines in the FRONT to the slots in the cabinet box, tap the FRONT on with a rubber mallet, making sure the cabinet FRONT is pressed firmly onto the cabinet box.
8. To attach HANGER CLEATS see page #3 of this manual.

